



LOWBOY, 55 TON
55LB940520



PRD: 00940520 A.1



LOWBOY, 55 TON

3+1 AXLE, DETACHABLE NON GROUND BEARING,
MAXIMUM PAYLOAD 110,000 LBS



HIGH QUALITY STEEL



Constructed with T-1 100K PSI yield strength Steel. The High Tensile Steel ensures the designed camber is retained, and allows for a longer product service life.

LIGHTING SYSTEM



All Lighting is LED and mounted in rubber grommets to DOT standards.

COLOR OPTIONS



Globe Trailers can powder coat to the color of your choice.

AIR BAGS



30K pound rated large diameter air bags are standard. This allows for lower operating pressure and higher capacity when needed.

22" DECK HEIGHT



With a standard deck height of 22", Globe Trailers have lower overall height, which allows taller loads to be hauled.

AIR TRANSITION RAMPS

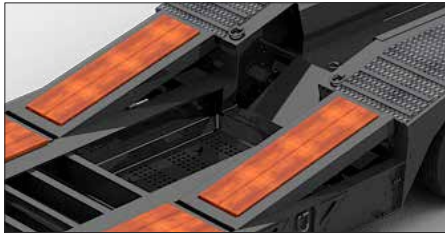

The Air Transition Ramps are recessed in the trailer deck and can quickly be activated to allow loading onto the upper deck.

FRONT RAMPS



Wood filled, adjustable, spring loaded Low angle paver ramps for easy loading onto the main deck.

DECKING OPTIONS



Oak: Standard.
Apitong: Best strength to weight ratios of natural woods.
Rumber: Composite which is impervious to fluids, mud, oil and UV rays.

STEMCO WHEEL WARRANTY



5 year wheel end warranty. Guardian wheel seals, Pro-Torq spindle nuts and Sentinel hub caps.

ADDED SECURITY



Globe Trailers air lock with safety bar and spring extended pin ensures that the gooseneck locking pin will remain secured even if air pressure is lost.

FLIP AXLE



Globe Trailers has a patent on the hydraulic flip axle design. It allows for less down time when operating the flip axle and it can be easily detached when required.

COLOR CODED HOSES



Color coded air hoses allow for easy trouble shooting and maintenance.

HEAVY DUTY FRONT OUTRIGGERS



Globe Trailers fabricated heavy duty pullout front outriggers provide added strength which is needed to accommodate the initial force when loading equipment. The outrigger is held in position with a spring loaded locking pin.

V-STYLE GUIDE



V-Style guide with front tapered beams helps position the gooseneck locking pin, which makes hooking up to a Globe Trailer fast and easy. The locking pin guide rim helps prevent the gooseneck locking pin from coming loose in transit.

CENTRALLY LOCATED FITTINGS



Air, electric and hydraulic (when applicable) fittings are all centrally located at the base of the gooseneck inside a bolster. This makes for quick and easy connect and disconnect. The fittings are protected from possible contact with equipment being loaded or unloaded.

MULTI POSITION RIDE HEIGHT



Multi Position Ride Height options. Makes adjustments for various 5th wheel heights easy and allows for larger ground clearance or lower deck height.

WARRANTY



Globe Trailer's 10 year structural warranty on all lowboys is the best in the industry. Most competitors offer only a 5 year warranty. This shows how committed Globe Trailers is to it's customers.

12" CROSS MEMBER SPACING

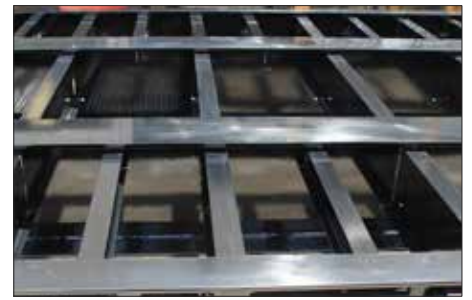

Standard 12" stubbed cross member spacing produces added strength to the trailer and also less stress on the decking, leading to a longer life of the decking material.

POLYURETHANE VS RUBBER BUSHING



Reduced Maintenance	Increased Maintenance
Increased Trailer Lifetime	Needs Replacement
Increased Trailer Performance	Reduces Trailer Performance
Weather Resistant	Damaged from Weather



All Globe Trailers are 100% powder coat finished. The entire process takes place at Globe's manufacturing facility. This eliminates the possibility of contamination occurring in transit between process phases. The process starts with sandblasting the trailer to near white, preheating the trailer steel in a dedicated, gas fired oven to optimum bonding temperature and applying an electrostatically charged zinc rich primer. The trailer then goes back in the oven to allow the primer to bond. After the primer has bonded, a top coat chosen from one of Globe Trailers' 188 color options is applied before once more going back in the oven to cure. The result is a durable, easily cleaned finish that protects the trailer from corrosion and ensures a long service life.

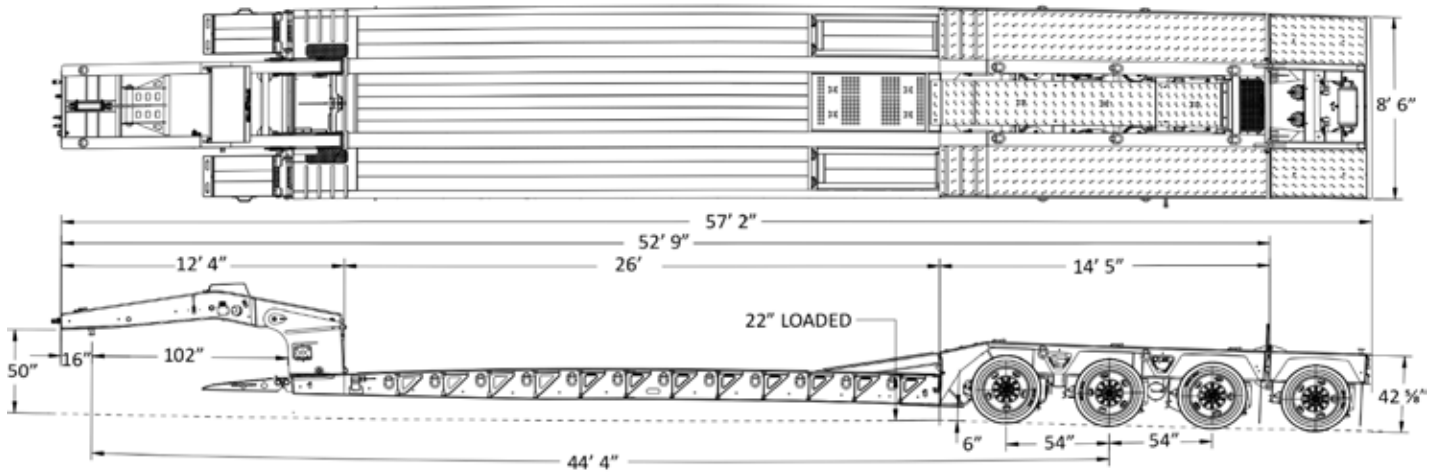

Trailer Model	GTBN553-53-26-HGG	Weight (Trailer + Flip Axle)	24,320 + 2,850 = 27,170 lbs
----------------------	-------------------	-------------------------------------	-----------------------------

Overall Length	Overall Width	Gooseneck Length	Lower Deck Length	Lower Deck Height	Rear Deck Length	Rear Deck Height	Ground Clearance
57' 2"	8' 6"	12' 4"	26'	22" loaded	14' 5"	42 5/8"	6"

Main Deck	
Main Beam	16" T-1 Steel Standard
Centers	40"
Side Rails	16" T-1 Steel
Crossmembers	10" & 4"
Spacing	12"
Outriggers	Full Height Removable
# Of D-Rings	12 Each Side
Front Ramps	Paver Ramps Adjustable width, 22" x 41"
Concentrated Load	110,000 lbs in 12'
Rear Deck	
Riser	90° w/6' Air Transition Ramps
Rear Deck Beam	16.5" T-1 Steel
Rear Well Style	Boom & Bucket Well
# of D-Rings	2 Each Side
Set up for Hydraulic Powered Flip	
Decking/Flooring	
Main Decking	1.75" Apitong Full Width
Wheel Covers	Steel Covered D-Plate
Well Decking	Removable D-PLate - Full Length
Electrical	
Lights	LED Plus 2 - Rear Strobes
Connector	7 Way Connector
Safety Night Light Package w/ Battery	
Tires & Rims	
Tires	255/70R x 22.5 "H"
Rims	8.25 x 22.5 Hub Piloted Outer Aluminum

Axles, Suspension, & Running Gear	
# of Axles	3+1
Axle Spacing	54"
Axle Capacity	25,000 lbs
Brakes	16 1/2" x 7" - 25K
ABS	2S1M
Axle 1	Fixed Type 30/30 Non-ABS
Axle 2	Fixed Type 30/30 ABS
Axle 3	Super Lift Type 30 Non-ABS
Axle 4	Hydraulic Flip Type 30 Non-ABS
Air Ride Suspension - 25K,	
Manual Dump, Air Ride Adjuster	
Gooseneck	
King Pin Style	Fixed
King Pin Setting	16"
Swing Clearance	102"
5th Wheel Height	50"
King Pin	2"
Ride Height	5-Position
Hydraulics	
Wet Line Kit - Wing Nut Connection	
13 HP Honda - Gas	
Finish	
Sandblast & Powder Coat	
Mud Flaps & Reflective Tape	
Flag Holders	

Dealer: