



DLA Contract  
SPE8EC-19-D-0039



GSA Contract  
GS-30F-0027R



DUMP, 30 TON, 30-YARD

30DD080114

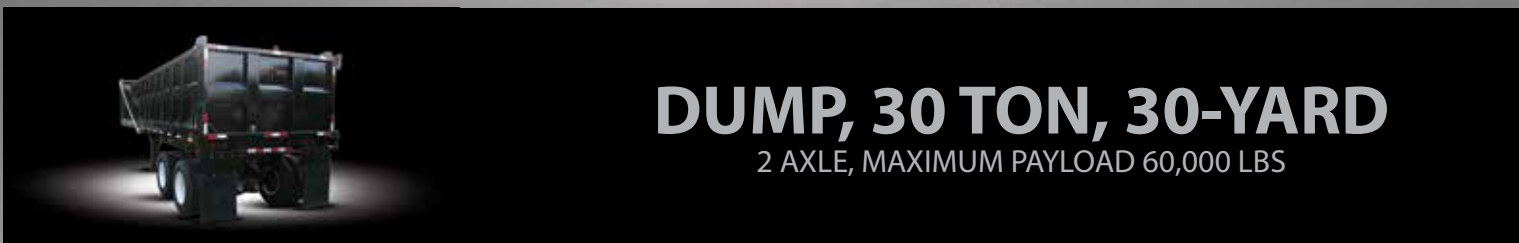

# DUMP, 30 TON, 30-YARD

2 AXLE, MAXIMUM PAYLOAD 60,000 LBS



## HYDRAULIC



The hydraulic lift cylinder allows and restricts the trailer dumping angle up to 45°, which is optimal for ejecting debris and maintaining a safe operating height.

## DROP DECK FEATURE



The drop deck allows for more volume and reduces overall height, also the trailer is safer than other trailers due to the lower center of gravity.

## TARP SYSTEM



Automatic Tarp system provided in cab controls makes operation fast and efficient in the field.



## TAIL GATE



Heavy Duty barn door type gate, hinges and lockable.

## COLOR OPTIONS



Globe Trailers can powder coat to the color of your choice.

## LIGHTING SYSTEM



All Lighting is LED and mounted in rubber grommets to DOT standards.



WHEEL OPTIONS



All Globe trailers come with standard HUB piloted disc wheels. Wheels are also available in all Aluminum or Outer Aluminum.

COLOR CODED HOSES



Color coded air hoses allow for easy trouble shooting and maintenance.

STEMCO WHEEL WARRANTY



5 year wheel end warranty. Guardian wheel seals, Pro-Torq spindle nuts and Sentinel hub caps.

LANDING GEAR



2 speed Landing Gear, allows for 160,000 lbs static load.



All Globe Trailers are 100% powder coat finished. The entire process takes place at Globe's manufacturing facility. This eliminates the possibility of contamination occurring in transit between process phases. The process starts with sandblasting the trailer to near white, preheating the trailer steel in a dedicated, gas fired oven to optimum bonding temperature and applying an electrostatically charged zinc rich primer. The trailer then goes back in the oven to allow the primer to bond. After the primer has bonded, a top coat chosen from one of Globe Trailers' 188 color options is applied before once more going back in the oven to cure. The result is a durable, easily cleaned finish that protects the trailer from corrosion and ensures a long service life.

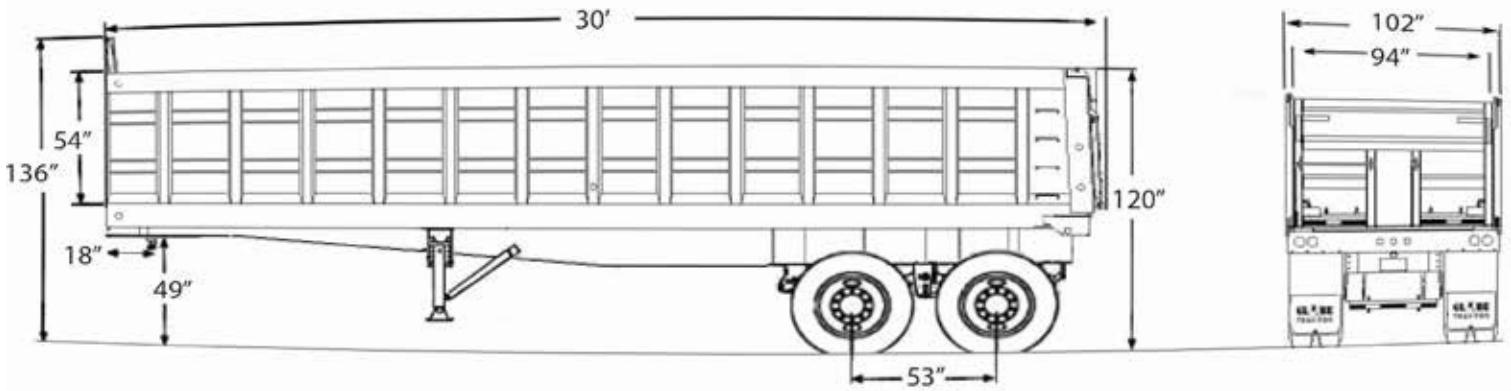

**Trailer Model: GTDD302-30-38Y**

**Weight: Apx. 17,500 ± lbs**

Overall Length	Overall Width	Interior Front Wall Height	Interior Rear Wall Height	Interior Width	Overall Height (Includes Tarp from Ground)	Overall Height (Tub only from Ground)
30' 0" (360")	8' 6" (102")	54"	54"	94"	11' 4" (136")	10' 0" (120")

Chassis	
King Pin Style	Fixed
King Pin Setting	18"
5th Wheel Height	49"
King Pin	2"
Main Beam	16" @ 57 I-Beam main frame.
Main Beam Centers	36"
Neck Beam	10" I-Beam Std.
Landing Gear	Dual 2-Speed
Tub/Frame	
Longitudinals	6" 10 gauge grade 50 steel full lengths.
Floor Sills	4" Channel on 12" centers.
Side Walls	GR50 3/16" Steel sides Std
Top Rail	3 x 3 x 1/4" Angle Std.
Floor	GR50 1/4" Steel
Angle on Floor	2 x 2 x 1/4" Std.
Rear Gate	
Rear Gate	Heavy Duty Barn Door Gate Std.
Locking Mechanism	Manually Lock
Gate Operation	Manually Operated
Electrical	
Lights	LED S/T/T Only
Connector	7 Way SAE connector
Tires & Rims	
Tires	11R x 22.5 "H"
Rims	8.25 x 22.5 Hub Piloted Steel

Axles, Suspension, & Running Gear	
# of Axles	2
Axle Spacing	53"
Axle Capacity	25,000 lbs
Brakes	16 1/2" x 7" - 25K
ABS	2S1M
Axle 1	Fixed Type 30/30 ABS
Axle 2	Fixed Type 30/30 Non-ABS
Suspension	Heavy duty single point spring ride suspension.
Hydraulics	
Wet Line Kit - Wing Nut Connection	
Tarp	
Automatic tarp system, with cab kit for in cab operation.	
Finish	
Sandblast & Powder Coat	
Mud Flaps & Reflective Tape	

**Dealer:**